

CD4001BM/CD4001BC Quad 2-Input NOR Buffered B Series Gate

CD4011BM/CD4011BC Quad 2-Input NAND Buffered B Series Gate

General Description

These quad gates are monolithic complementary MOS (CMOS) integrated circuits constructed with N- and P-channel enhancement mode transistors. They have equal source and sink current capabilities and conform to standard B series output drive. The devices also have buffered outputs which improve transfer characteristics by providing very high gain.

All inputs are protected against static discharge with diodes to V_{DD} and V_{SS} .

Features

- Low power TTL compatibility
 - 5V–10V–15V parametric ratings
 - Symmetrical output characteristics
 - Maximum input leakage 1 μ A at 15V over full temperature range
- Fan out of 2 driving 74L or 1 driving 74LS

Schematic Diagrams

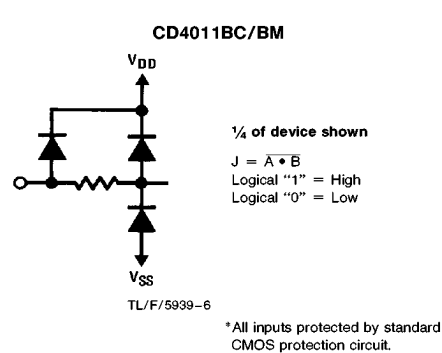
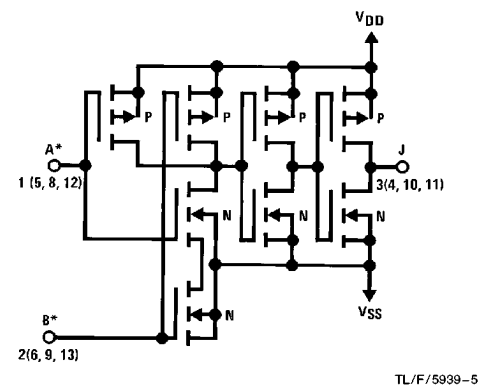
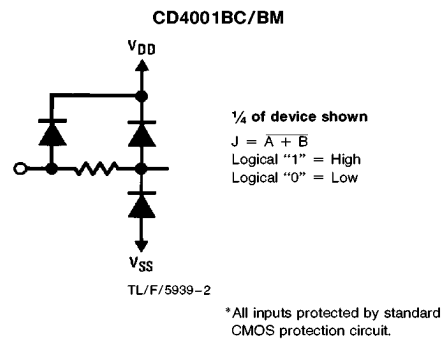
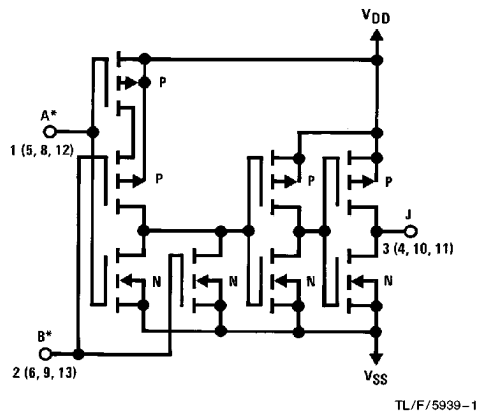

CD4001BM/CD4001BC Quad 2-Input NOR Buffered B Series Gate
 CD4011BM/CD4011BC Quad 2-Input NAND Buffered B Series Gate

Absolute Maximum Ratings (Notes 1 and 2)

If Military/Aerospace specified devices are required, please contact the National Semiconductor Sales Office/Distributors for availability and specifications.

Voltage at any Pin	-0.5V to $V_{DD} + 0.5V$
Power Dissipation (P_D)	
Dual-In-Line	700 mW
Small Outline	500 mW
V_{DD} Range	-0.5 V_{DC} to +18 V_{DC}
Storage Temperature (T_S)	-65°C to +150°C
Lead Temperature (T_L)	
(Soldering, 10 seconds)	260°C

Operating Conditions

Operating Range (V_{DD})	3 V_{DC} to 15 V_{DC}
Operating Temperature Range	
CD4001BM, CD4011BM	-55°C to +125°C
CD4001BC, CD4011BC	-40°C to +85°C

DC Electrical Characteristics CD4001BM, CD4011BM (Note 2)

Symbol	Parameter	Conditions	-55°C		+25°C			+125°C		Units
			Min	Max	Min	Typ	Max	Min	Max	
I_{DD}	Quiescent Device Current	$V_{DD} = 5V, V_{IN} = V_{DD}$ or V_{SS}		0.25		0.004	0.25		7.5	μA
		$V_{DD} = 10V, V_{IN} = V_{DD}$ or V_{SS}		0.50		0.005	0.50		15	μA
		$V_{DD} = 15V, V_{IN} = V_{DD}$ or V_{SS}		1.0		0.006	1.0		30	μA
V_{OL}	Low Level Output Voltage	$V_{DD} = 5V$		0.05		0	0.05		0.05	V
		$V_{DD} = 10V$		0.05		0	0.05		0.05	V
		$V_{DD} = 15V$		0.05		0	0.05		0.05	V
V_{OH}	High Level Output Voltage	$V_{DD} = 5V$	4.95		4.95	5		4.95		V
		$V_{DD} = 10V$	9.95		9.95	10		9.95		V
		$V_{DD} = 15V$	14.95		14.95	15		14.95		V
V_{IL}	Low Level Input Voltage	$V_{DD} = 5V, V_O = 4.5V$		1.5		2	1.5		1.5	V
		$V_{DD} = 10V, V_O = 9.0V$		3.0		4	3.0		3.0	V
		$V_{DD} = 15V, V_O = 13.5V$		4.0		6	4.0		4.0	V
V_{IH}	High Level Input Voltage	$V_{DD} = 5V, V_O = 0.5V$	3.5		3.5	3		3.5		V
		$V_{DD} = 10V, V_O = 1.0V$	7.0		7.0	6		7.0		V
		$V_{DD} = 15V, V_O = 1.5V$	11.0		11.0	9		11.0		V
I_{OL}	Low Level Output Current (Note 3)	$V_{DD} = 5V, V_O = 0.4V$	0.64		0.51	0.88		0.36		mA
		$V_{DD} = 10V, V_O = 0.5V$	1.6		1.3	2.25		0.9		mA
		$V_{DD} = 15V, V_O = 1.5V$	4.2		3.4	8.8		2.4		mA
I_{OH}	High Level Output Current (Note 3)	$V_{DD} = 5V, V_O = 4.6V$	-0.64		-0.51	-0.88		-0.36		mA
		$V_{DD} = 10V, V_O = 9.5V$	-1.6		-1.3	-2.25		-0.9		mA
		$V_{DD} = 15V, V_O = 13.5V$	-4.2		-3.4	-8.8		-2.4		mA
I_{IN}	Input Current	$V_{DD} = 15V, V_{IN} = 0V$		-0.10		-10 ⁻⁵	-0.10		-1.0	μA
		$V_{DD} = 15V, V_{IN} = 15V$		0.10		10 ⁻⁵	0.10		1.0	μA

Connection Diagrams

CD4001BC/CD4001BM
Dual-In-Line Package

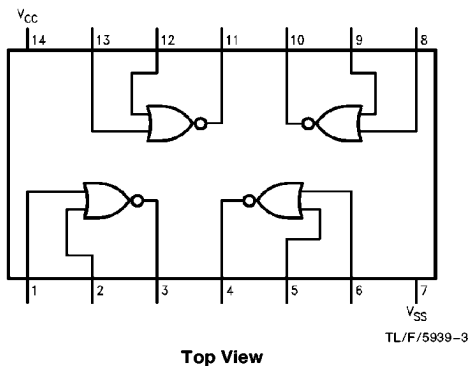

CD4011BC/CD4011BM
Dual-In-Line Package

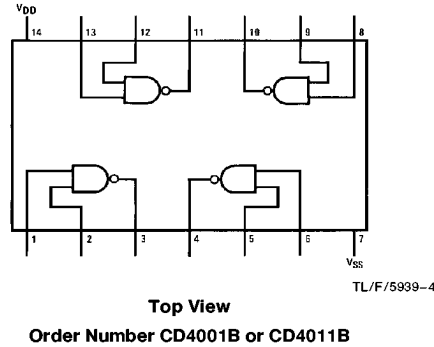

DC Electrical Characteristics CD4001BC, CD4011BC (Note 2)

Symbol	Parameter	Conditions	-40°C		+25°C			+85°C		Units
			Min	Max	Min	Typ	Max	Min	Max	
I _{DD}	Quiescent Device Current	V _{DD} = 5V, V _{IN} = V _{DD} or V _{SS}		1		0.004	1		7.5	μA
		V _{DD} = 10V, V _{IN} = V _{DD} or V _{SS}		2		0.005	2		15	μA
		V _{DD} = 15V, V _{IN} = V _{DD} or V _{SS}		4		0.006	4		30	μA
V _{OL}	Low Level Output Voltage	V _{DD} = 5V } I _O < 1 μA		0.05		0	0.05		0.05	V
		V _{DD} = 10V }		0.05		0	0.05		0.05	V
		V _{DD} = 15V }		0.05		0	0.05		0.05	V
V _{OH}	High Level Output Voltage	V _{DD} = 5V } I _O < 1 μA	4.95		4.95	5		4.95		V
		V _{DD} = 10V }	9.95		9.95	10		9.95		V
		V _{DD} = 15V }	14.95		14.95	15		14.95		V
V _{IL}	Low Level Input Voltage	V _{DD} = 5V, V _O = 4.5V		1.5		2	1.5		1.5	V
		V _{DD} = 10V, V _O = 9.0V		3.0		4	3.0		3.0	V
		V _{DD} = 15V, V _O = 13.5V		4.0		6	4.0		4.0	V
V _{IH}	High Level Input Voltage	V _{DD} = 5V, V _O = 0.5V	3.5		3.5	3		3.5		V
		V _{DD} = 10V, V _O = 1.0V	7.0		7.0	6		7.0		V
		V _{DD} = 15V, V _O = 1.5V	11.0		11.0	9		11.0		V
I _{OL}	Low Level Output Current (Note 3)	V _{DD} = 5V, V _O = 0.4V	0.52		0.44	0.88		0.36		mA
		V _{DD} = 10V, V _O = 0.5V	1.3		1.1	2.25		0.9		mA
		V _{DD} = 15V, V _O = 1.5V	3.6		3.0	8.8		2.4		mA
I _{OH}	High Level Output Current (Note 3)	V _{DD} = 5V, V _O = 4.6V	-0.52		-0.44	-0.88		-0.36		mA
		V _{DD} = 10V, V _O = 9.5V	-1.3		-1.1	-2.25		-0.9		mA
		V _{DD} = 15V, V _O = 13.5V	-3.6		-3.0	-8.8		-2.4		mA
I _{IN}	Input Current	V _{DD} = 15V, V _{IN} = 0V		-0.30		-10 ⁻⁵	-0.30		-1.0	μA
		V _{DD} = 15V, V _{IN} = 15V		0.30		10 ⁻⁵	0.30		1.0	μA

AC Electrical Characteristics* CD4001BC, CD4001BM

T_A = 25°C, Input t_r; t_f = 20 ns. C_L = 50 pF, R_L = 200k. Typical temperature coefficient is 0.3%/°C.

Symbol	Parameter	Conditions	Typ	Max	Units
t _{PHL}	Propagation Delay Time, High-to-Low Level	V _{DD} = 5V	120	250	ns
		V _{DD} = 10V	50	100	ns
		V _{DD} = 15V	35	70	ns
t _{PLH}	Propagation Delay Time, Low-to-High Level	V _{DD} = 5V	110	250	ns
		V _{DD} = 10V	50	100	ns
		V _{DD} = 15V	35	70	ns
t _{THL} , t _{TLH}	Transition Time	V _{DD} = 5V	90	200	ns
		V _{DD} = 10V	50	100	ns
		V _{DD} = 15V	40	80	ns
C _{IN}	Average Input Capacitance	Any Input	5	7.5	pF
C _{PD}	Power Dissipation Capacity	Any Gate	14		pF

*AC Parameters are guaranteed by DC correlated testing.

Note 1: "Absolute Maximum Ratings" are those values beyond which the safety of the device cannot be guaranteed. Except for "Operating Temperature Range" they are not meant to imply that the devices should be operated at these limits. The table of "Electrical Characteristics" provides conditions for actual device operation.

Note 2: All voltages measured with respect to V_{SS} unless otherwise specified.

Note 3: I_{OL} and I_{OH} are tested one output at a time.

AC Electrical Characteristics* CD4011BC, CD4011BM
 $T_A = 25^\circ\text{C}$, Input t_i ; $t_f = 20$ ns. $C_L = 50$ pF, $R_L = 200\text{k}$. Typical Temperature Coefficient is $0.3\%/^\circ\text{C}$.

Symbol	Parameter	Conditions	Typ	Max	Units
t_{PHL}	Propagation Delay, High-to-Low Level	$V_{DD} = 5\text{V}$	120	250	ns
		$V_{DD} = 10\text{V}$	50	100	ns
		$V_{DD} = 15\text{V}$	35	70	ns
t_{PLH}	Propagation Delay, Low-to-High Level	$V_{DD} = 5\text{V}$	85	250	ns
		$V_{DD} = 10\text{V}$	40	100	ns
		$V_{DD} = 15\text{V}$	30	70	ns
t_{THL}, t_{TLH}	Transition Time	$V_{DD} = 5\text{V}$	90	200	ns
		$V_{DD} = 10\text{V}$	50	100	ns
		$V_{DD} = 15\text{V}$	40	80	ns
C_{IN}	Average Input Capacitance	Any Input	5	7.5	pF
C_{PD}	Power Dissipation Capacity	Any Gate	14		pF

*AC Parameters are guaranteed by DC correlated testing.

Typical Performance Characteristics

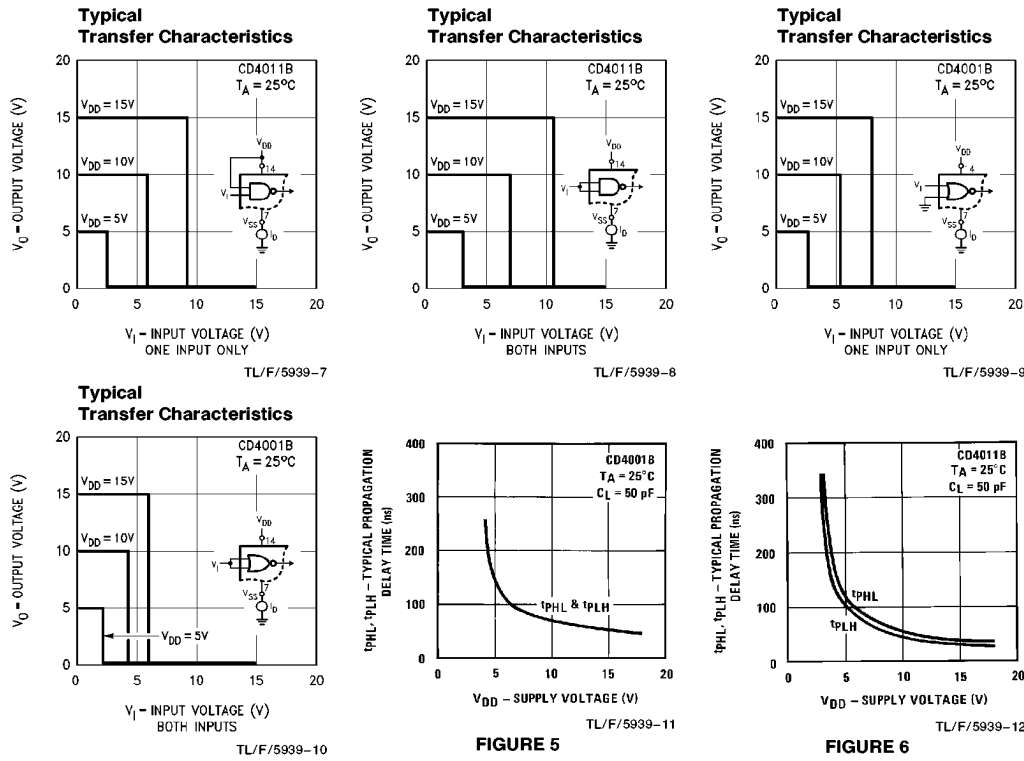

Typical Performance Characteristics (Continued)

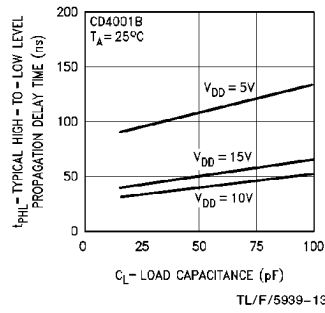

FIGURE 7

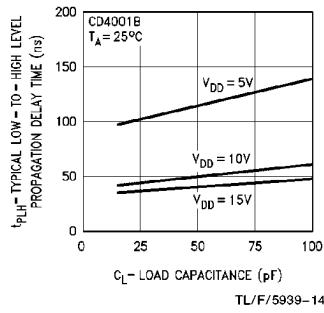

FIGURE 8

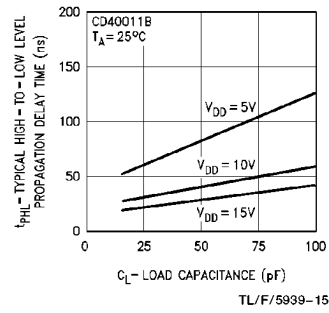

FIGURE 9

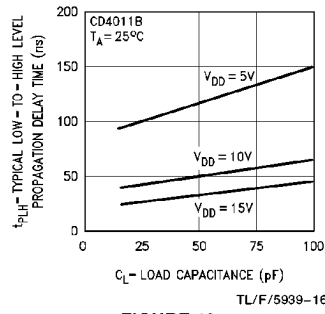

FIGURE 10

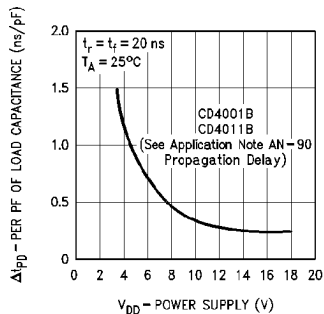

FIGURE 11

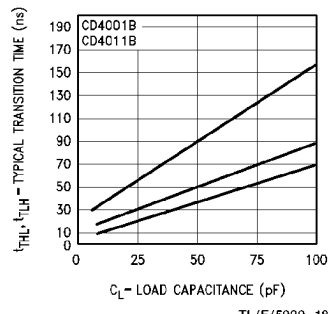

FIGURE 12

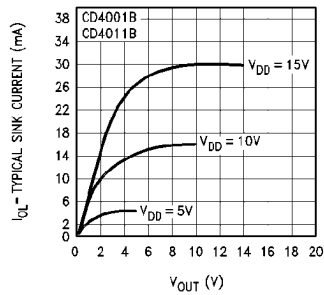

FIGURE 13

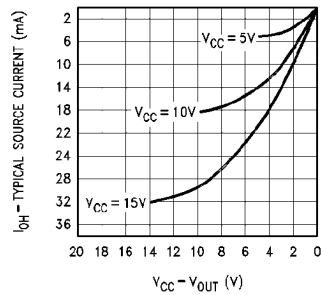
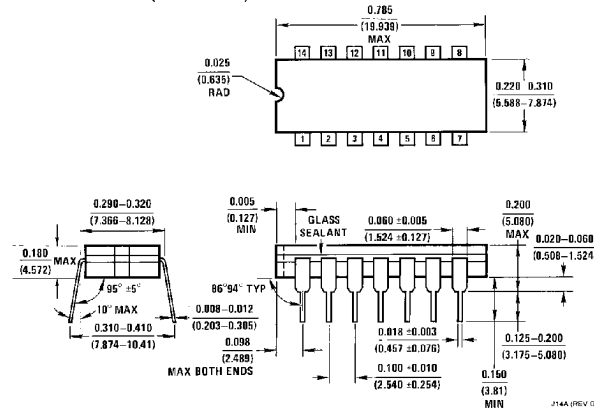

FIGURE 14

CD4001BM/CD4001BC Quad 2-Input NOR Buffered B Series Gate
CD4011BM/CD4011BC Quad 2-Input NAND Buffered B Series Gate

Physical Dimensions inches (millimeters)



Ceramic Dual-In-Line Package (J)
Order Number CD4001BMJ, CD4001BCJ, CD4011BMJ or CD4011BCJ
NS Package Number J14A

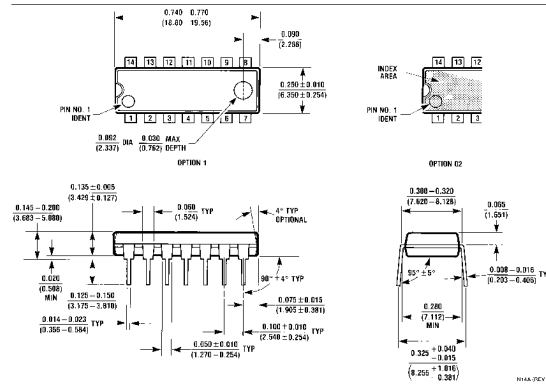

Molded Dual-In-Line Package (N)
Order Number CD4001BMN, CD4001BCN, CD4011BMN or CD4011BCN
NS Package Number N14A

LIFE SUPPORT POLICY

NATIONAL'S PRODUCTS ARE NOT AUTHORIZED FOR USE AS CRITICAL COMPONENTS IN LIFE SUPPORT DEVICES OR SYSTEMS WITHOUT THE EXPRESS WRITTEN APPROVAL OF THE PRESIDENT OF NATIONAL SEMICONDUCTOR CORPORATION. As used herein:

1. Life support devices or systems are devices or systems which, (a) are intended for surgical implant into the body, or (b) support or sustain life, and whose failure to perform, when properly used in accordance with instructions for use provided in the labeling, can be reasonably expected to result in a significant injury to the user.
2. A critical component is any component of a life support device or system whose failure to perform can be reasonably expected to cause the failure of the life support device or system, or to affect its safety or effectiveness.



National Semiconductor Corporation
 1111 West Bardin Road
 Arlington, TX 76017
 Tel: 1(800) 272-9959
 Fax: 1(800) 737-7018

National Semiconductor Europe
 Fax: (+49) 0-180-530 85 86
 Email: cnjwge@tevm2.nsc.com
 Deutsch Tel: (+49) 0-180-530 85 85
 English Tel: (+49) 0-180-532 78 32
 Français Tel: (+49) 0-180-532 93 58
 Italiano Tel: (+49) 0-180-534 16 80

National Semiconductor Hong Kong Ltd.
 13th Floor, Straight Block,
 Ocean Centre, 5 Canton Rd.
 Tsimshatsui, Kowloon
 Hong Kong
 Tel: (852) 2737-1600
 Fax: (852) 2736-9960

National Semiconductor Japan Ltd.
 Tel: 81-043-299-2309
 Fax: 81-043-299-2406

National does not assume any responsibility for use of any circuitry described, no circuit patent licenses are implied and National reserves the right at any time without notice to change said circuitry and specifications.