



LS285

TELEPHONE SPEECH CIRCUITS

The LS285 is monolithic integrated circuits for replacement of the hybrid circuit (2-4 wire interface) in conventional telephones interfacing the two transducers to the line and providing a controlled amount of sidetone.

The same type of transducer can be used for both transmitter and receiver, usually a 350Ω dynamic type.

By sensing the line current, LS285 adjusts the gain in both directions to compensate for line attenuation.

Output impedance can be matched to the line, independent of transducer impedance.

The LS285 is packaged in a 14 lead dual in-line plastic package.

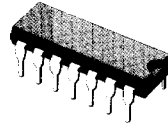

DIP-14 Plastic
(0.4)

ORDERING NUMBER: U37070

BLOCK DIAGRAM

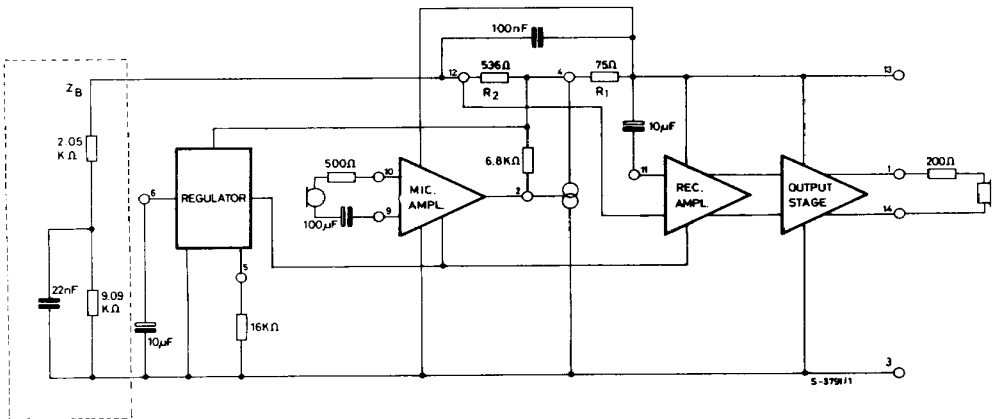

LS285

ABSOLUTE MAXIMUM RATINGS

V_L	Line voltage (3 ms pulse duration)	22	V
I_L	Forward current	120	mA
I_L	Reverse current	-150	mA
P_{tot}	Total power dissipation at $T_{amb} = 70^\circ\text{C}$	1	W
T_{stg}	Storage and junction temperature	-55 to 150	$^\circ\text{C}$
T_{op}	Operating temperature	-40 to 70	$^\circ\text{C}$

CONNECTION DIAGRAM (top view)

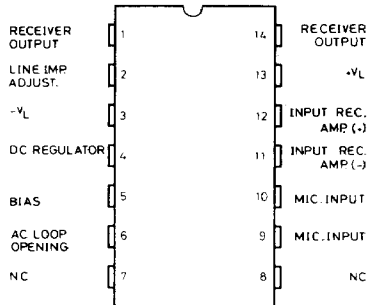

5-4029

THERMAL DATA

$R_{th\ j-amb}$	Thermal resistance junction-ambient	max	80	$^\circ\text{C/W}$
-----------------	-------------------------------------	-----	----	--------------------

DESCRIPTION

The LS285 is based on a bridge configuration. They contain a regulator block, a sending amplifier and a receiver amplifier. The regulator monitors the line current and adjusts the amplifier gain to compensate for the line length. It provides DC characteristics in line with CEPT standards. The transmit/receiver amplifiers are connected to the line via an external bridge to provide sidetone attenuation. The line current compensation ensures that when the subscriber is talking, the signal delivered to the line is increased in according to the line length. When he is hearing, the signal level on the receiver capsule is constant. The amplifiers can also be matched to different transducers simply by varying external components. Gain variation over the operating temperature range is less than ± 1 dB. The impedance to the line can be adjusted; without any change in circuit parameters; by changing an external resistor (6.8 K Ω at pin 2).

Basic circuit configuration

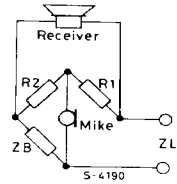

Fig. 1 - Test circuit

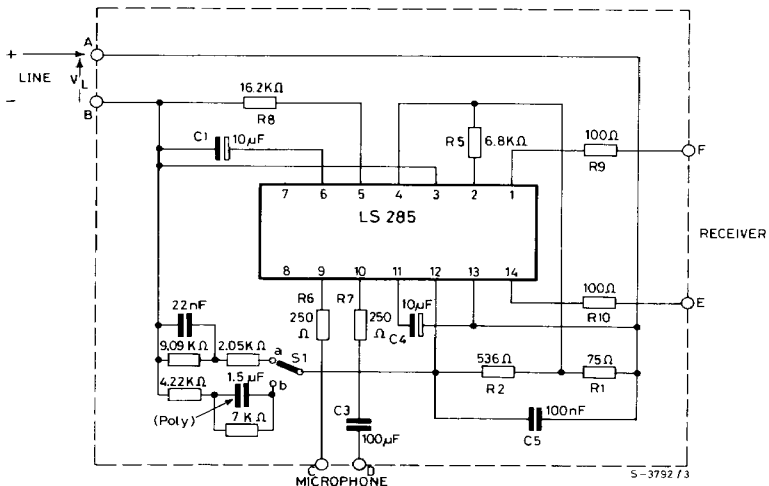
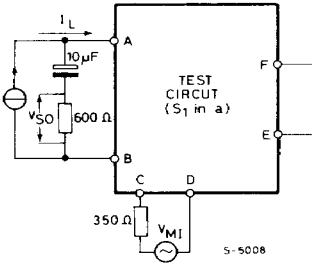
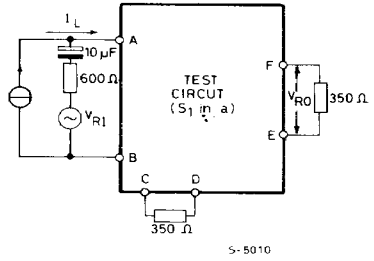

Fig. 2 - Sending gain



$$G_S = \frac{V_{S0}}{V_{M1}}$$

Fig. 3 - Receiving gain



$$G_R = \frac{V_{RO}}{V_{R1}}$$

Fig. 4 - Sidetone

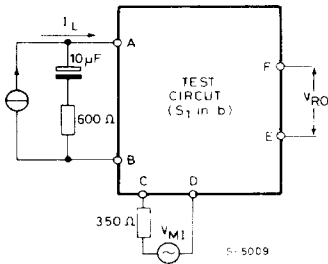

$$\text{Sidetone} = \frac{V_{RO}}{V_{M1}}$$

Fig. 5 - Return loss

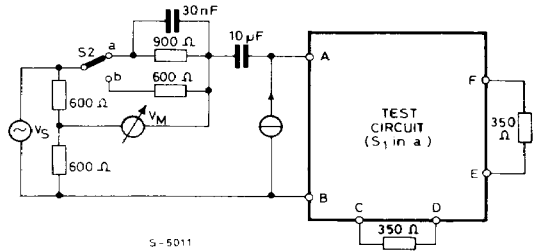

$$R_L = \frac{V_s}{2 V_M}$$

ELECTRICAL CHARACTERISTIC (Refer to the test circuit, $T_{amb} = 25^{\circ}\text{C}$, $f = 300\text{ Hz to } 3400\text{ Hz}$, S1, S2 in "a" unless otherwise specified)

Parameter	Test Conditions	Min.	Typ.	Max.	Unit	Fig.
V_L Line voltage	$-15^{\circ}\text{C} < T_{amb} < +45^{\circ}\text{C}$ $I_L = 80\text{ mA}$ $I_L = 20\text{ mA}$ $I_L = 10\text{ mA}$	10 5 3.8		11.5 5.8 4.6	V	1
G_S Sending gain	$f = 1\text{ KHz}$ $I_L = 15\text{ mA}$ $I_L = 30\text{ mA}$ $I_L = 60\text{ mA}$ $I_L = 80\text{ mA}$	47.5 46.4 41.7 41		51.5 50.5 45.1 44.3	dB	2
G_S Sending gain variation vs. temp.	$-15^{\circ}\text{C} < T_{amb} < +45^{\circ}\text{C}$		0.8		dB	2
Sending gain flatness	$I_L = 10\text{ to } 80\text{ mA}$ $f_{ref} = 1\text{ KHz}$ S1, S2 in (b)			± 0.5	dB	2
Sending distortion	$-15^{\circ}\text{C} < T_{amb} < +45^{\circ}\text{C}$ $I_L = 10\text{ to } 15\text{ mA}$ $V_{so} = 0.7V_p$			2	%	2
	$-15^{\circ}\text{C} < T_{amb} < +45^{\circ}\text{C}$ $I_L = 15\text{ to } 80\text{ mA}$ $V_{so} = 1 V_p$			2	%	
Sending noise	$V_{MI} = 0V$ $I_L = 60\text{ mA}$		-73		dBmp	2
Microphone amplifier impedance (pin 9-10)		95			Ω	1
Max sending output (°)	$I_L = 10\text{ to } 80\text{ mA}$ $V_{MI} = 1V$			3	V_p	2
G_R Receiving gain	$f = 1\text{ KHz}$ $I_L = 15\text{ mA}$ $I_L = 30\text{ mA}$ $I_L = 60\text{ mA}$ $I_L = 80\text{ mA}$	-13.6 -13.6 -18 -19		-9.9 -10.6 -14.9 -16	dB	3
ΔG_R Receiving gain variation vs. temperature	$-15^{\circ}\text{C} < T_{amb} < +45^{\circ}\text{C}$		0.25		dB	3
Receiving gain flatness	$f_{ref} = 1\text{ KHz}$ $I_L = 10\text{ to } 80\text{ mA}$ S1, S2 in (b)			± 0.5	dB	3

(°) This output is limited to allow for input overvoltages.

LS285

ELECTRICAL CHARACTERISTICS (continued)

Parameter	Test Conditions	Min.	Typ.	Max.	Unit	Fig.
Receiving distortion	$-15^{\circ}\text{C} < T_{\text{amb}} < +45^{\circ}\text{C}$ $I_L = 10 \text{ to } 15 \text{ mA}$ $V_{RO} = 350 \text{ mV}_p$			2	%	3
		$I_L = 15 \text{ to } 80 \text{ mA}$ $V_{RO} = 500 \text{ mV}_p$		2		
Receiving amplifier output impedance (pin 1-14)			110		Ω	1
Receiving noise	$V_{RI} = 0 \text{ V}$ $I_L = 60 \text{ mA}$ psophometric		80		μV	3
Max receiving output current	$I_L = 80 \text{ mA}$ $V_{RI} = 10 \text{ V}$			3.6	mAp	3
Sidetone	$f = 1 \text{ KHz}$ $I_L = 20 \text{ mA}$		7		dB	4
		$I_L = 80 \text{ mA}$		0	dB	
Return loss	S3 in (a)		14		dB	5
	S3 in (b)		14		dB	

(*) This output is limited to allow for input overvoltages.

Fig. 6 - Typical application circuit

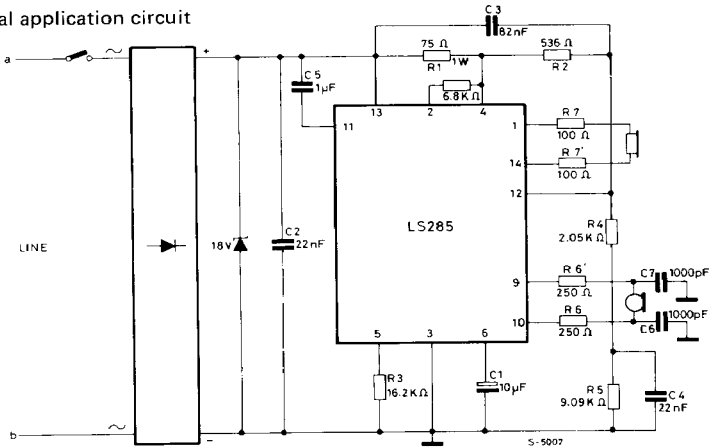

APPLICATION INFORMATION

The following table shows the recommended values for the typical application circuit of fig. 6. Different values can be used and notes are added in order to help designer.

Component	Recommended Value	Purpose	Note
R1	75 Ω	Bridge resistors	The ratio R2/R1 fixes the amount of the signal delivered to the line. (see fig. 7)
R2	536 Ω		
R3	16.2 KΩ	Bias resistor	Changing R3 value it is possible to shift the gain characteristics. The value can be chosen from 15 KΩ to 20 KΩ. The recommended value assures the maximum swing (see fig. 9).
R4	2.05 KΩ	Balance network	In order to optimize the sidetone it is possible to change R4 and R5 values. In any case: $\frac{Z_B}{Z_L} = \frac{R2}{R1}$ where $Z_B = R4 + R5/C4$.
R5	9.09 KΩ		
R6 and R6'	250 Ω	Microphone impedance matching	R6 and R6' must be equal; 250Ω is a typical value for dynamic capsules. Furthermore, they determine a sending gain variation according to: $\Delta G_s = 20 \log \frac{R_x}{850\Omega}$ where $R_x = R6 + R6' + R_{mike}$. The trend of ΔG_s as a function of R_x value is shown in fig. 8.
R7 and R7'	100 Ω	Receiver impedance matching	R7 and R7' must be equal; 100Ω is a typical value for dynamic capsules
C1	10 μF	AC loop opening	Ensures a high regulator impedance for AC signals ($\cong 20 K\Omega$). This capacitor should not be higher than 10 μF in order to have a short response time of the system.
C2	22 nF	Matching to a capacitive line	C2 changes with the characteristics of the transmission line.
C3	82 nF	High frequency roll-off	C3 determines the high frequency response of the circuit. It also acts as RF bypass.
C4	22 nF	Balance network	See note for R4 and R5.
C5	1 μF	DC decoupling for receiving input	
C6 and C7	1000 pF	RF bypass	

LS285

APPLICATION INFORMATION (continued)

Fig. 7 - Receiving gain variation vs. R1 value (with fixed R1/R2 ratio)

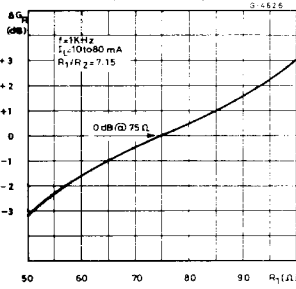

Fig. 8 - Sending gain variation vs. R_x value (see note for R_6 and R_6')

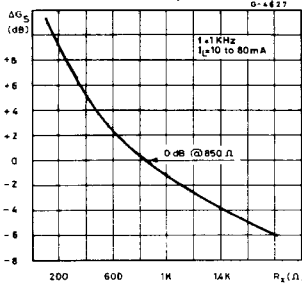

Fig. 9 - Sending and receiving gain variation vs. line current

